

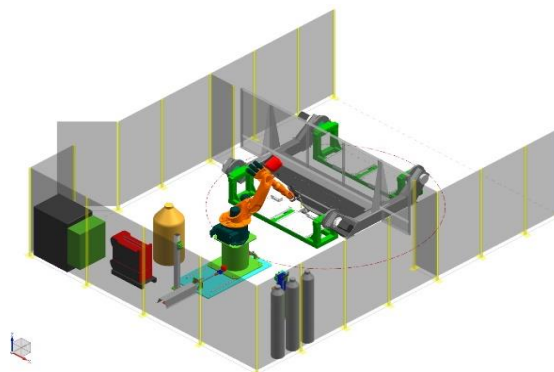

ROBOTIC WELDING CELL Art. CS2

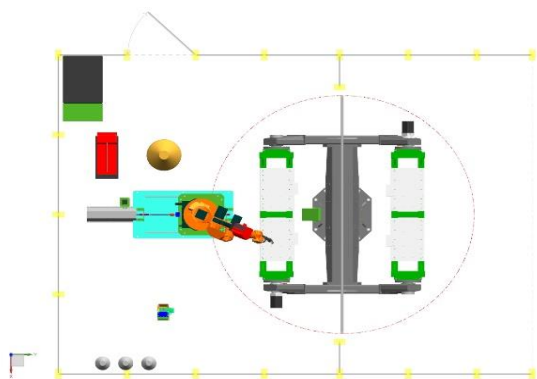

UNIT	UNIT DESCRIPTION	Q.TY	PRICE
00	Development of layout, system design	1	
10	Lathe with two positioners	1	
20	Robot	1	
30	Welding machine	1	
100	Electric cabinet	1	
110	Electric system	1	
120	Protection guards	1	
130	Pneumatic system	1	
140	Installation of SISTEC sub-assemblies	1	
150	Trial and internal test at SISTEC	1	

SUB-TOTAL, EX-WORKS

€ 125.000,00

UNIT	EXCLUSIONS AND OPTIONAL
00	Development of software for system management
160	Welding jigs
170	Installation, wiring, tests and debug
180	Start-up and final test