

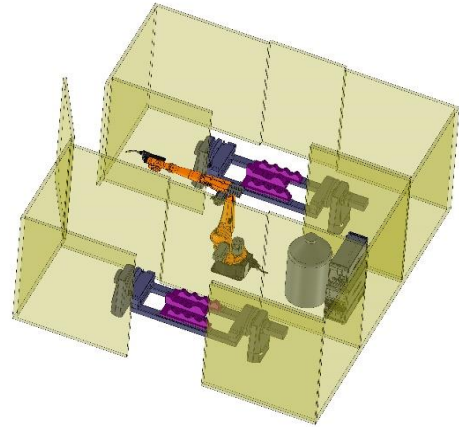

ROBOTIC WELDING CELL
Art. CS2T

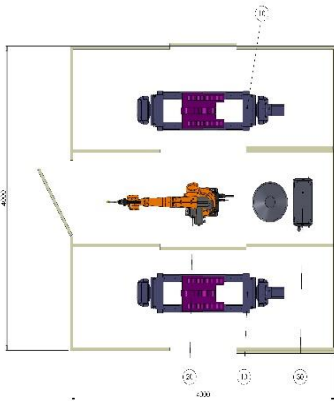

UNIT	UNIT DESCRIPTION	Q.TY	PRICE
00	Development of layout, system design	1	
10	Single welding lathe	2	
20	Welding Robot	1	
30	Welding machine	1	
100	Electric cabinet	1	
110	Electric system	1	
120	Protection guards	1	
130	Pneumatic system	1	
140	Installation of SISTEC sub-assemblies	1	
150	Trial and internal test at SISTEC	1	
SUB-TOTAL, EX-WORKS			€ 125,000.00
UNIT	OPTIONAL	Q.TY	PREZZO
00	Supervisor software HMI "OP SIS 2.0"	1	€ 8,000.00
UNIT	EXCLUSIONS		
00	Development of software for system management and welding path for one piece		
00	Software off-line		
160	Installation, wiring and start-up		